

REVISIONS			
REV	DESCRIPTION	DATE	APPROVED
A	108.00 WAS 144.00, 114.25 WAS 150.25, WEIGHT WAS 1,640 LB. ADDED NOTE 8 ABOUT BEAM	08-13-15	DAH

This document contains the proprietary information of Tandemloc, Inc. and your access and use shall be, and is at all times, pursuant to and limited by the Tandemloc, Inc. Terms of Use.

You shall not, and shall not encourage, assist, or authorize another party to copy, distribute, publicly display, modify, reverse engineer, decompile, or take any other action to reproduce this document or the information contained herein.

©2019 by Tandemloc, Inc.  
Dimensions are subject to manufacturing tolerance and change.

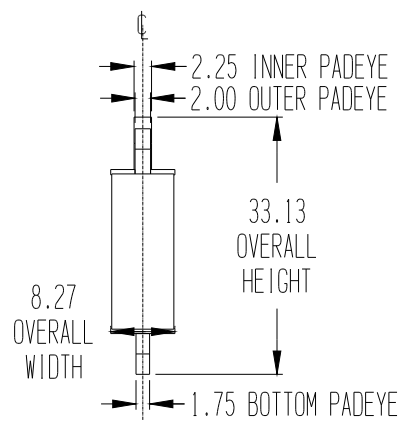
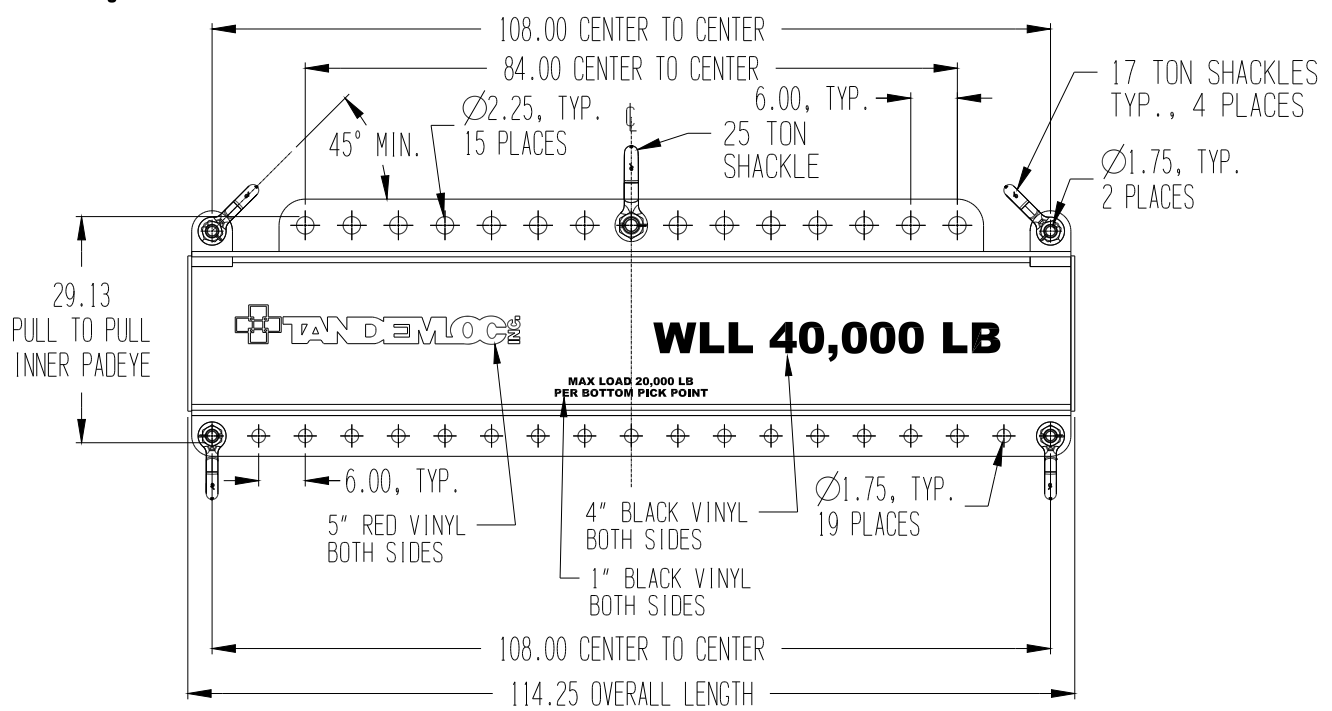

- NOTES:
- PART NO.: AL50G00-00A-PA, 20 TON WLL LIFT BEAM WITH SHACKLES  
AL50G00-NSA-PA, 20 TON WLL LIFT BEAM NO SHACKLES
  - WLL: 20T (40,000 LB.)
  - PROOF TESTED TO 150% (60,000 LB.) AND CERTIFIED
  - STANDARD SPECIFICATION # EAD21000A APPLIES
  - FINISH: SANDBLAST, PRIME AND PAINT SAFETY YELLOW
  - CALCULATED WEIGHT: 1,460 LB. W/ SHACKLES 1,352 LB. W/OUT SHACKLES
  - DESIGNED AND MANUFACTURED TO MEET OR EXCEED ASME B30.20 AND BTH-1, DESIGN CATEGORY B, SERVICE CLASS O.
  - BEAM SHALL BE W21X68 MIN.

**\*\* DO NOT SIGN IF CHANGES ARE REQUIRED \*\***

CUSTOMER APPROVAL: \_\_\_\_\_

DATE: \_\_\_\_\_

<input checked="" type="checkbox"/> "X" DENOTES APPLICABLE DATA UNLESS OTHERWISE NOTED. DIMENSIONS ARE IN INCHES & TOLERANCES ARE: .XX ±.00    .XXXX ±.0007 .XXX ±.03		<input type="checkbox"/> "X" DENOTES APPLICABLE DATA LOST WAX CASTING TOL. IS: 0 TO 4" ±.030", 4.01" TO 7" ±.038" 7.01" TO 10.5" ±.045" OVER 10.5" ±.052"			
THIS DOCUMENT CONTAINS DATA WHICH IS EITHER PATENTED, PATENT PENDING OR IS THE PROPERTY OF TANDEMLOC, INC. DISCLOSURE, OR COPYING WITHOUT THE WRITTEN AUTHORIZATION OF TANDEMLOC, INC. IS EXPRESSLY PROHIBITED.				TITLE: AL50G00-00A-PA 20 TON WLL LIFT BEAM	
APPROVALS: _____ DATE: 08-11-15 DRAWN: JML		SIZE: D CASE CODE: 65059 SCALE:	DWG NO.: SAL50G00	REV: A	SHEET 1 OF 1